

SOVET

ITALIA



Palace

collection booklet

collection booklet

Palace

Design **Lievore Altherr Molina**

“
Palace dining table and its unique design become the outright protagonist of the living area, thanks also to the new shapes. An important element that sets the mood of the whole room.

Il tavolo Palace, grazie al suo design inconfondibile e alle nuove forme, diventa il protagonista assoluto dello spazio giorno: un elemento importante che caratterizza l'intero ambiente.

”

Models & Dimensions

Dining table with lacquered metal base, various finishes, or burnished finish. Tempered or laminated top in different measures, materials and finishes.

Tavolo con base in metallo laccato, varie finiture, o brunito. Top temperato o stratificato in varie misure, materiali e finiture.

rectangular

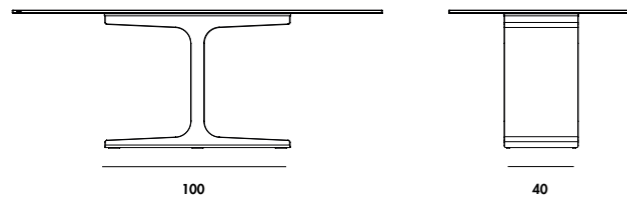

160x100x74h
200x100x74h
250x100x74h
240x120x74h

elliptical

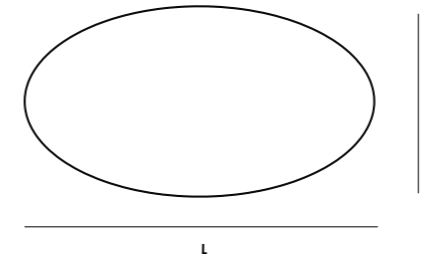
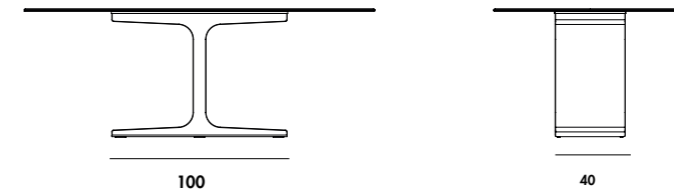

200x110x74h
220x130x74h

botte

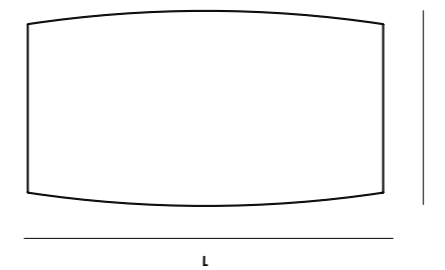
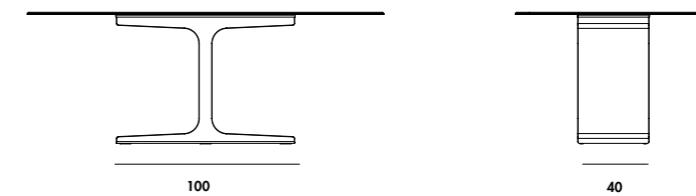

200x110x74h

shaped

180x100x74h
 220x115x74h
 250x120x74h
 300x135x74h

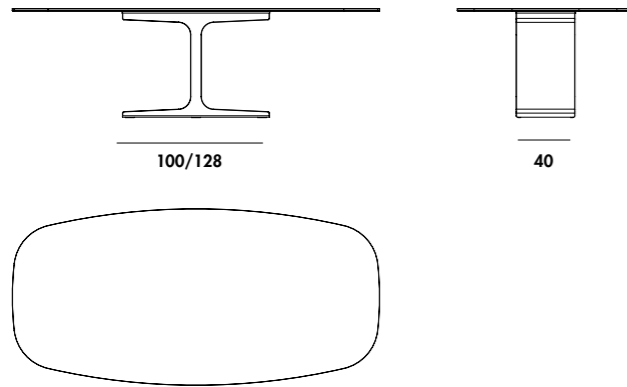

rectangular extensible

Close 140x90x76,5h
 170x90x76.5h
 200x100x76.5h
 220x100x76.5h

Open 140x90x76,5h
 250x90x76.5h
 280x100x76.5h
 300x100x76.5h

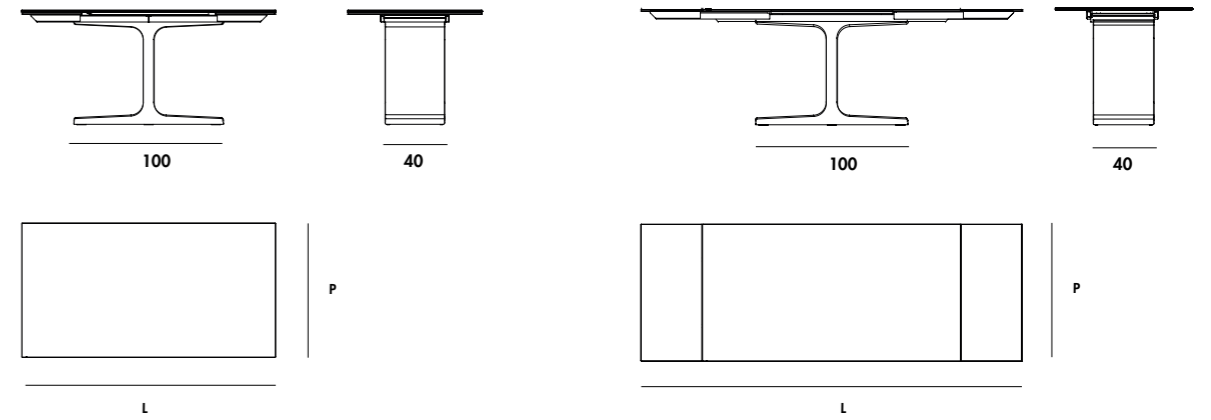

MAXI

460x140x75h

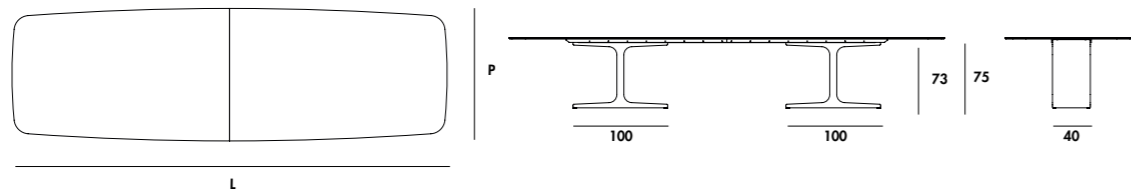

shaped extensible

Close 140x100x76.5h
 170x100x76.5h
 200x100x76.5h
 200x115x76.5h
 220x115x76.5h

Open 220x100x76.5h
 250x100x76.5h
 280x100x76.5h
 280x115x76.5h
 300x115x76.5h

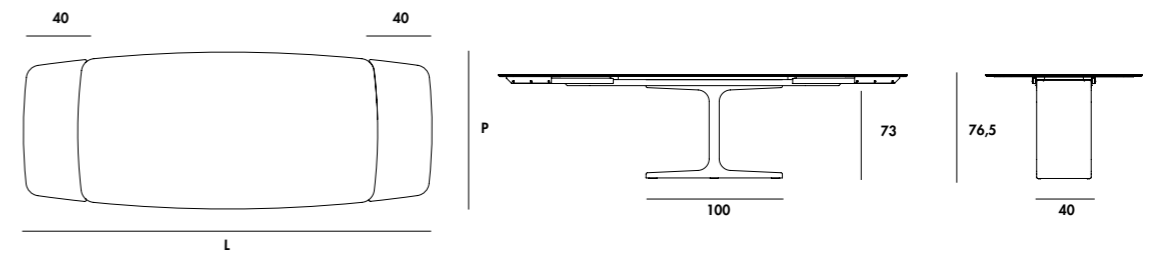

collection
finishes



TOP

Vetro Glass Cat. B



TEB1 Vetro extrachiaro laccato bianco latte
Extralight glass lacquered milky white

TEC1 Vetro extrachiaro laccato caffè
Extralight glass lacquered mocha

TEC2 Vetro extrachiaro laccato creta
Extralight glass lacquered clay

TEC3 Vetro extrachiaro laccato col. cemento
Extralight glass lacquered cement

TER4 Vetro extrachiaro laccato col. ruggine
Extralight glass lacquered rust

TEV2 Vetro extrachiaro laccato col. muschio
Extralight glass lacquered moss green



TEN1 Vetro extrachiaro laccato nero
Extralight glass lacquered black



TEM6 Vetro extrachiaro laccato col. tabacco
Extralight glass lacquered tobacco



TES1 Vetro extrachiaro laccato champagne
Extralight glass lacquered champagne



AEB1 Vetro acidato bianco
Frosted white glass



AEC2 Vetro acidato creta
Frosted clay glass



AEC3 Vetro acidato col. cemento
Frosted cement glass



AES1 Vetro acidato champagne
Frosted champagne glass

10

Vetro Glass Cat. D

Vetro acidato Frosted glass Cat. E

Net Glass

Cat. N

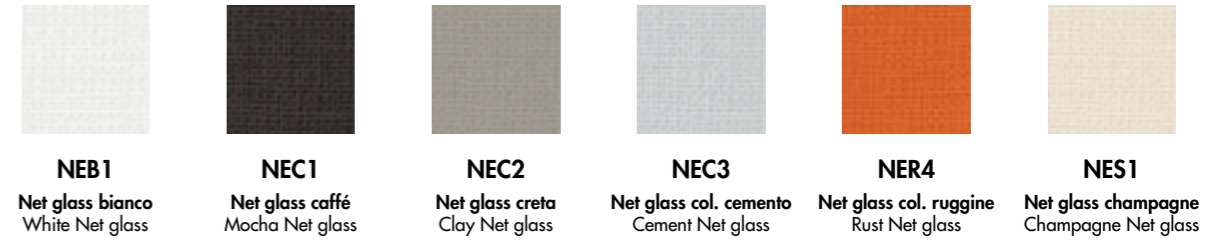

NEB1 Net glass bianco
White Net glass

NEC1 Net glass caffè
Mocha Net glass

NEC2 Net glass creta
Clay Net glass

NEC3 Net glass col. cemento
Cement Net glass

NER4 Net glass col. ruggine
Rust Net glass

NES1 Net glass champagne
Champagne Net glass



NEV2 Net glass col. muschio
Moss green Net glass

NEN1 Net glass nero
Black Net glass

NEM6 Net glass col. tabacco
Tobacco Net glass

Liquid glass/ Materia

Cat. SC

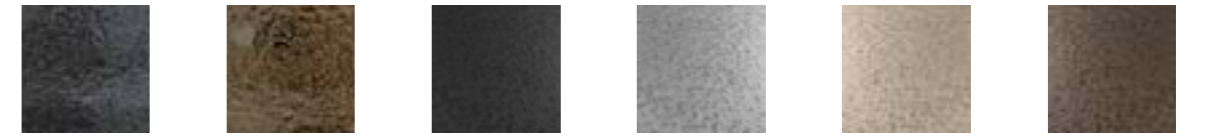

LFSP Liquid Glass fumè specchio
Smoked liquid glass mirrored

LBSP Liquid Glass bronzo specchio
Bronzed liquid glass mirrored

MFN1 Materia fumè nero
Smoked black materia

MESP Materia extrachiaro specchio
Extralight mirror materia

MES1 Materia extrachiaro champagne
Extralight champagne materia

MBSP Materia bronzo specchio
Mirrored bronzed materia



MSN1 Materia lucido fumè nero
Smoked glossy black materia

MLSP Materia extrachiaro lucido specchio
Extralight glossy mirrored materia

MLS1 Materia extrachiaro lucido champagne
Extralight glossy champagne materia

MLM7 Materia extrachiaro lucido bronzo
Extralight glossy bronzed materia

Legni Woods



NC Noce canaletto
Canaletto walnut

RN Rovere naturale
Natural oak wood

RG Rovere tinto grigio
Grey-stained oak

WG Rovere tinto wengè
Wengè-stained oak

11

Ceramica
Ceramic
Categoria CE1

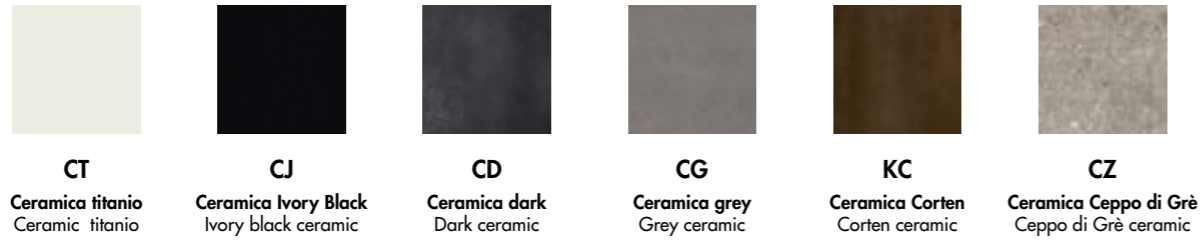

CT Ceramica titanio
Ceramic titanio

CJ Ceramica Ivory Black
Ivory black ceramic

CD Ceramica dark
Dark ceramic

CG Ceramica grey
Grey ceramic

KC Ceramica Corten
Corten ceramic

CZ Ceramica Ceppo di Grè
Ceppo di Grè ceramic



CC Ceramica Calacatta Prelucidata
Pre-polished Calacatta ceramic

CX Ceramica Stone Grey Prelucidata
Pre-polished Stone Grey ceramic

KR Ceramica breccia reale
Breccia reale ceramic

KB Ceramica travertino stone beige
Travertino stone beige ceramic

Ceramica
Ceramic
Categoria CE2/CE3

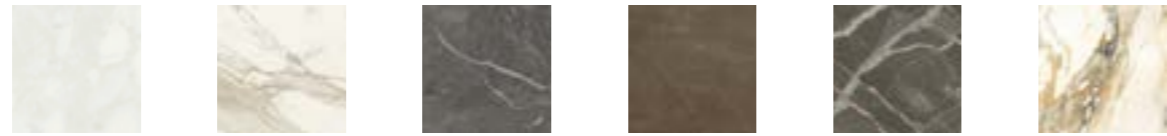

CA Ceramica Arabescato light
Arabescato light ceramic

CL Ceramica Calacatta lucida
Polished Calacatta ceramic

CY Ceramica Stone grey lucida
Polished Stone grey ceramic

CU Ceramica Gaudi Stone
Gaudi Stone ceramic

CV Ceramica Ombra di Caravaggio
Ombra di Caravaggio ceramic

CW Ceramica Antique
Antique ceramic

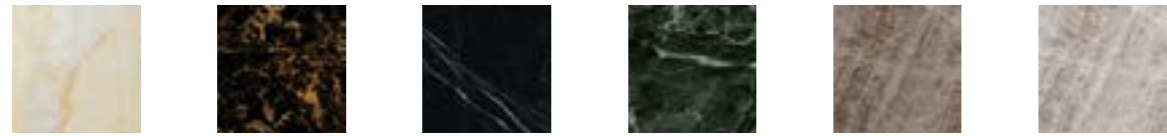

CI Ceramica Onice oro
Gold Onyx ceramic

KO Ceramica Black Gold
Black gold ceramic

CQ Ceramica Marquinia lucida
Polished Marquinia ceramic

KV Ceramica Verde Aver
Aver Green ceramic

KM Ceramica Yamuna moka
Yamuna moka ceramic

KY Ceramica Yamuna opal
Yamuna opal ceramic

Dekton
Categoria DE1

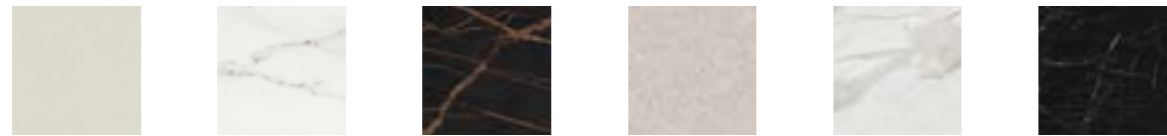

D01 Aeris Dekton
Dekton Aeris

D02 Rem Dekton
Dekton Rem

D03 Laurent Dekton
Dekton Laurent

D04* Nebbia Dekton
Dekton Nebbia

D05 Morpheus Dekton
Dekton Morpheus

D06 Somnia Dekton
Dekton Somnia



D07* Umber Dekton
Dekton Umber

D08* Sirius Dekton
Dekton Sirius

* Dekton D04 / D07 / D08 non disponibili in larghezza superiore a 140 cm.
Dekton D04 / D07 / D08 not available in widths exceeding 140 cm.

BASE

Metalli
Metals



GB Bianco goffrato
Embossed white

GC Caffè goffrato
Embossed mocha

GT Creta goffrato
Embossed clay

GN Nero goffrato
Embossed black

GS Sabbia goffrato
Embossed sand

BR Metallo brunito
Burnished metal

		VETRO GLASS	VETRO ACIDATO GLASS FROSTED	NET GLASS	CERAMICA CERAMIC	LEGNO WOOD	LIQUID GLASS	LIQUID GLASS/ MATERIA	DEKTON
	P1578	220x115x74h	15 FL	15 FL	12 FL	15 FL 45°(6+8)	12 BC	12 BC L / 12 BC	15 FL 45°(8+6)
	P1579	250x120x74h	15 FL	15 FL	12 FL	15 FL 45°(6+8)	12 BC	12 BC L / 12 BC	15 FL 45°(8+6)
	P1580	300x135x74h	15 FL	15 FL	12 FL	15 FL 45°(6+8)	12 BC	12 BC L / 12 BC	15 FL 45°(8+6)
	P1564	200x100x74h	15 FL	15 FL		15 FL 45°(6+8)			15 FL 45°(8+6)
	P1566	250x100x74h	15 FL	15 FL		15 FL 45°(6+8)			15 FL 45°(8+6)
	P1559	240x120x74h	15 FL	15 FL		15 FL 45°(6+8)	24 F 45°		15 FL 45°(8+6)
	P1568	200x110x74h	12 FL 45°	12 FL 45°		15 FL 45°(6+8)			15 FL 45°(8+6)
	P1556	200x110x74h	12 FL 45°	12 FL 45°		15 FL 45°(6+8)			15 FL 45°(8+6)
	P1557	220x130x74h	12 FL 45°	12 FL 45°		15 FL 45°(6+8)			15 FL 45°(8+6)
	P1561	170x100x76,5h Extensible	12 FL	12 FL	12 FL	13 FL 45°(6+6)			15 FL 45°(8+6)
	P1562	200x100x76,5h Extensible	12 FL	12 FL	12 FL	13 FL 45°(6+6)			15 FL 45°(8+6)
	P1570	200x115x76,5h Extensible	12 FL	12 FL	12 FL	13 FL 45°(6+6)			15 FL 45°(8+6)
	P1571	220x115x76,5h Extensible	12 FL	12 FL	12 FL	13 FL 45°(6+6)			15 FL 45°(8+6)
	P1572	170x90x74h Extensible	12 FL	12 FL	12 FL	13 FL 45°(6+6)			15 FL 45°(8+6)
	P1575	200x100x74h Extensible	12 FL	12 FL	12 FL	13 FL 45°(6+6)			15 FL 45°(8+6)
	P1576	220x110x74h Extensible	12 FL	12 FL	12 FL	13 FL 45°(6+6)			15 FL 45°(8+6)
	P7120	460x140x75h	12 FL	12 FL	12 FL	15 FL 45°(6+8)	12 FL	12 FL	15 FL 45°(8+6)

Vetro

Le laccature utilizzate non presentano problemi di durata: basta evitare graffi e urti contro oggetti particolarmente duri e spigolosi. Il vetro è colorato solo sulla faccia posteriore sia nei vetri laccati coprenti mono e bicolore che nei vetri acidati laccati. La tonalità dei campioni proposti è indicativa e non va pertanto intesa in senso restrittivo; può infatti differire leggermente in conformità ai margini di tolleranza riconosciuti per i materiali impiegati. I materiali impiegati possono essere puliti tranquillamente solo con acqua oppure con un detergente neutro. Evitare l'uso di abrasivi, acidi o reagenti chimici. Il vetro è interpretato attraverso la sua trasparenza, pertanto la conformità al campione può differire a seconda della superficie e degli spessori impiegati. Un esempio lampante è dato dal vetro extrachiaro che nei campioncini si presenta completamente neutro ma che nei piani di dimensioni maggiori e con spessori più consistenti assume sfumature azzurro/verdi. Per tale ragione vi preghiamo anche di segnalare con particolare attenzione articoli che debbano essere affiancati o facenti parte di una stessa commissione.

La finitura bicolore consiste nella doppia laccatura nella parte interna della lastra di vetro. La prima laccatura, visibile attraverso la trasparenza del vetro, è disponibile nelle categorie B-D. La seconda laccatura, visibile internamente, equivale al colore pastello opaco utilizzato per ottenere le finiture di cat. B. Vi facciamo presente che in questo caso l'effetto finale differisce da quello creato dalla medesima laccatura attraverso il vetro, in particolare nei colori tenui.

Specchi

Gli specchi oro e rosa potrebbero presentare delle piccole imperfezioni dovute alle caratteristiche tecniche del materiale. Non possono essere utilizzati in luoghi umidi. Pulire solo con panni asciutti.

Ceramica

I campioni riportati sono una parte delle lastre che vengono lavorate. La lastra completa si può vedere nella corrispondente cartella. Pulire utilizzando acqua e una piccola quantità di detergente neutro. Evitare l'utilizzo di detergenti contenenti cere e prodotti ceranti per evitare la formazione di strati untuosi.

Legno

I colori dei legni sono campioni indicativi. Pulire utilizzando un panno morbido inumidito.

Metalli

I colori dei metalli sono campioni indicativi. Pulire utilizzando un panno morbido inumidito.

Tessuti/Pelli/Ecopelli/Velluti

I colori dei tessuti sono campioni indicativi. Per la cura e la manutenzione fare riferimento alle indicazioni riportate nelle rispettive cartelle e alle schede tecniche fornite dai produttori.

Se permangono dubbi contattare l'azienda.

Glass

The lacquering used for our furniture is extremely durable as long as you avoid scratching it or bumping particularly hard/sharp objects against it. The glass is lacquered only on the back side both for mono or two-tones lacquered and frosted lacquered glasses. The shade of the samples is only indicative and has not to be taken as restrictive. It can in fact slightly differ in conformity to the tolerances recognized for the materials used. All the materials we use can be easily cleaned with water only or with a mild detergent. Do not use abrasive materials, acids or harsh chemicals. The glass is interpreted through its transparency, therefore the conformity to the sample might differ according to the surface and the thickness used. For example, the extralight glass is completely neutral when seen in the small samples, but it takes a light blue/greenish shade when used on bigger or thicker tops. For this reason, we beg you to indicate carefully those articles which have to be placed side by side or which are part of the same commission.

The two-tones finish consists of a double lacquering on the internal part of the glass sheet. The first lacquering, which is visible through the transparency of the glass, is available in the finishes of cat. B-D. The second lacquering, which is visible internally, is the same of the mat pastel used to get the finishes of cat. B. Please notice that the final effect is different from the one created by the same lacquering through the glass, in particular when it comes to soft colours.

Mirrors

Gold and rose mirrors could have small imperfections due to the particular technical characteristics of the material. We recommend not to use them in damp areas. Clean only with a dry cloth.

Ceramic

The shown samples are part of the bigger slabs Sovet works with. The complete slab is visible in the corresponding folder. Clean using water and a small amount of neutral detergent. Avoid using detergents with wax and waxing products to avoid the formation of greasy layers.

Wood

Wood colours are indicative samples. Clean using a damp soft cloth.

Metals

Metals colours are indicative samples. Clean using a damp soft cloth.

Fabrics/Leathers/Fake leathers/velvets

Fabrics colours are indicative samples. For care and maintenance please refer to the instructions present in the corresponding folders and to the technical sheets provided by the manufacturers.

In case of further doubt please get in touch with the factory.

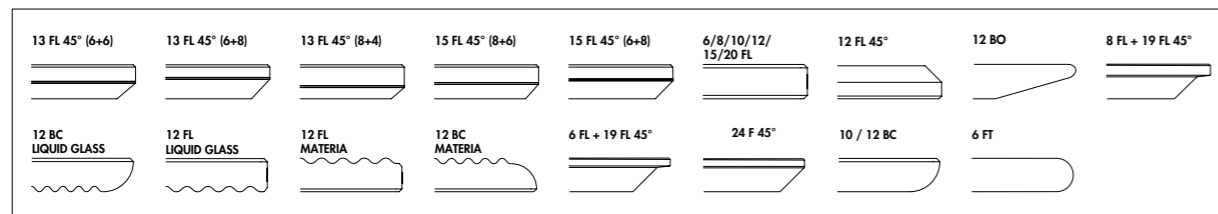





Palace base BR top CA.
Pura chairs in Kvadrat hallingdal 153.



In the previous pages Palace shaped base GC top CU
and Autumn chairs in NF and P54 seat.



Palace shaped base BR top CO.
Autumn chairs structure DF seat P53.

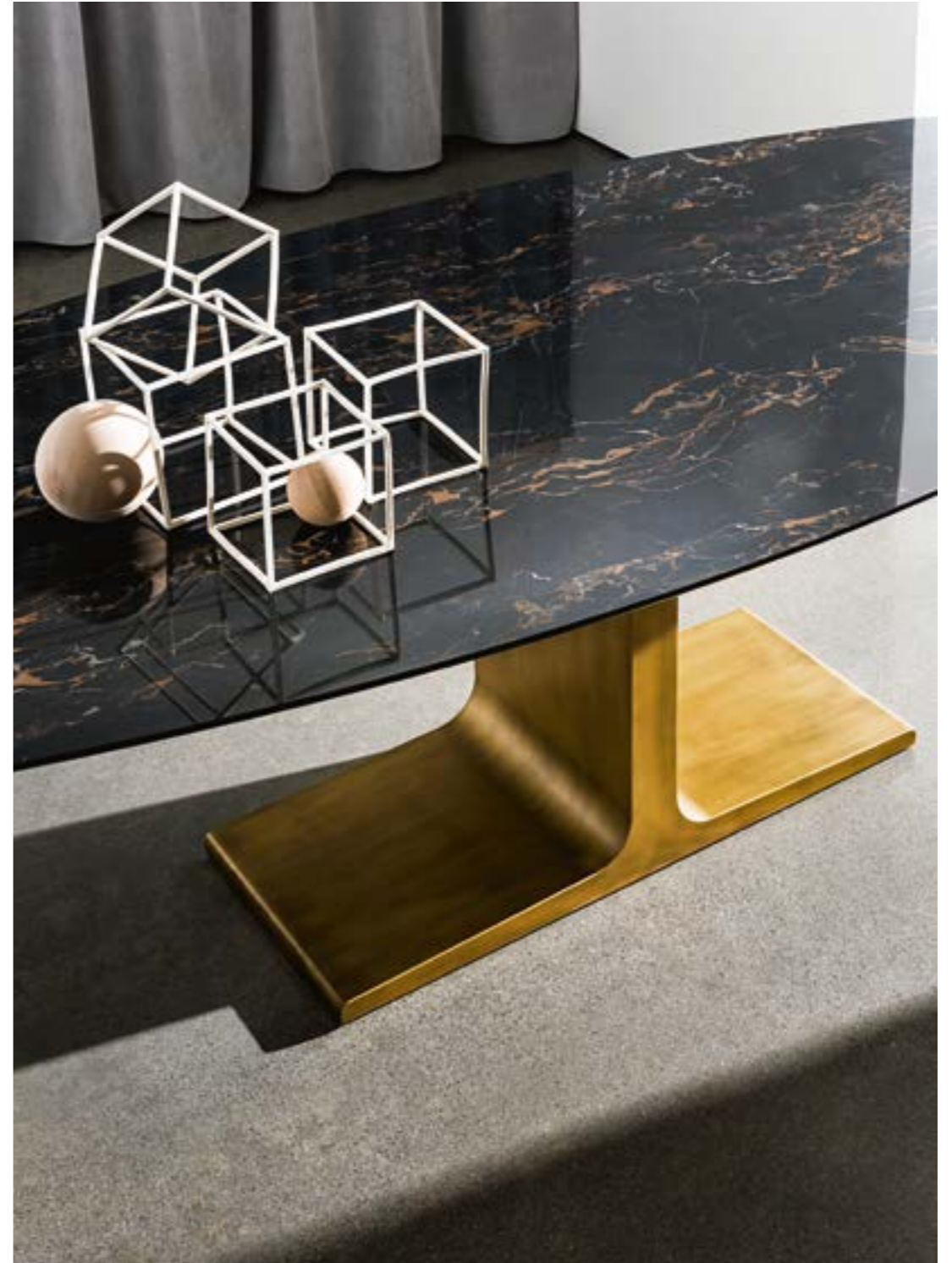

Palace shaped base BR top CO.



Palace shaped base GN top CQ.
Cadeira cone shaped base GN velvet Z06.
Madia Slim base GN structure WG.



Palace shaped base GN top CQ.
 Cadira cone shaped base GN velvet Z06.

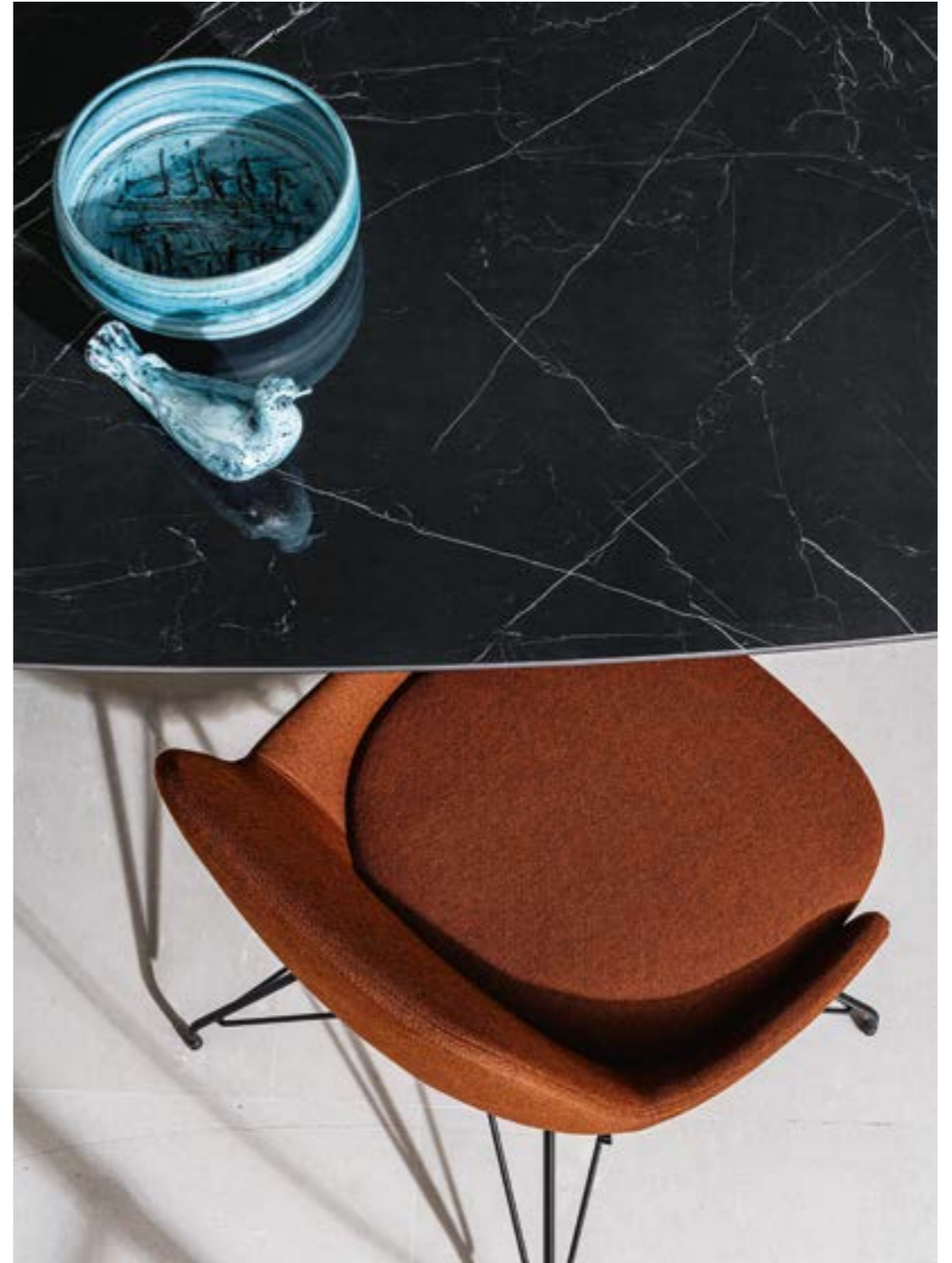

Palace shaped base GN top CQ.
 Cadira s wire base GN Trevira F05.





A long, rectangular dining table with a dark green marble top and a large, circular mirror mounted on the wall behind it. The table is supported by a dark, curved metal base. On the table, there is a vase with greenery, a stack of books, and a small decorative object.

Four contemporary chairs with light-colored, textured upholstery and thin metal frames are arranged around the table. The chairs have a modern, curved design.

A large, circular mirror with a dark, curved metal frame is mounted on the wall behind the table. The mirror reflects the room and the table.

A tall, clear glass vase containing a small green plant with delicate leaves, placed on the table.

A stack of three books, with the top one open, placed on the table next to the vase.

A small, round, textured decorative object, possibly a candle or a small sculpture, placed on the table.

designer

Lievore Altherr Molina

Lievore Altherr Molina, was founded by Alberto Lievore, Jeannette Altherr and Manel Molina in 1991. The Studio focuses on product design, consultancy and art direction work for a number of companies, offering personalized solutions to industry. Known by its furniture design, it also develops interior design projects, packaging and product design. In many opportunities, the Studio gives seminars and courses cooperating with several Spanish universities in forming new professionals. It currently works for firms in Spain, Italy and the United States, outstanding its projects for companies such as Andreu World, Arketipo, Arper, Arruti, Bellato, Bernhardt, Casamilano, Do+Ce, Dona, Emmebi, Foscari, Halifax, Metalarte, Orizzonti, Perobell, Poltrona Frau, Roda, Santa & Cole, Segis, Sellex, Sovet, Sunroller, Tacchini, Tisettanta, Verzelloni, Vibia, etc. Award-winner with Spanish National Design Award (1999) it has received numerous awards and special mentions, both in Spain and abroad, for its work, including several ADI-FAD Deltas Gold and Silver. It has held both individual and joint exhibitions in Barcelona, Cologne, Chicago, Stockholm, Helsinki, Lisbon, London, Louisiana, Madrid, Malmö, Milan, New York, Paris and Tokyo. Its designs are featured regularly in Spanish and international trade magazines.

Lo Studio Lievore Altherr Molina è composto da Alberto Lievore, Jeannette Altherr e Manel Molina, che hanno formato una società nel 1991. Lo Studio si dedica all'industrial design, alla consulenza e alla direzione d'arte di diverse ditte, offrendo soluzioni personalizzate alle aziende. Conosciuto per i suoi progetti d'arredamento, sviluppa inoltre progetti di design d'interni, packaging e industrial design. Oltre a tali attività, si ricorda la docenza esercitata in seminari, workshop e conferenze, presso diverse Università spagnole aiutando la formazione di nuovi professionisti. Attualmente svolge attività in Spagna, Italia e Stati Uniti, collaborando con aziende come Andreu World, Arketipo, Arper, Arruti, Bellato, Bernhardt, Casamilano, Do+Ce, Dona, Emmebi, Foscari, Halifax, Metalarte, Orizzonti, Perobell, Poltrona Frau, Roda, Santa & Cole, Segis, Sellex, Sovet, Sunroller, Tacchini, Tisettanta, Verzelloni, Vibia, etc. Lo studio ha ricevuto numerosi premi e riconoscimenti nazionali e internazionali per i lavori svolti, tra cui il Premio Nacional de Diseño (1999) e diversi Delta de Oro e Delta de Plata dell'ADI-FAD. Ha realizzato mostre personali ed esposizioni a Barcellona, Colonia, Chicago, Stoccolma, Helsinki, Lisbona, Londra, in Louisiana, a Madrid, Malmö, Milano, New York, Parigi e Tokyo. I lavori vengono pubblicati regolarmente su tutte le riviste specializzate nazionali ed estere.



sustainability is made up of facts.

Sovet has always maintained a high attention to eco-compatibility since its birth in 1987, through the selection of raw materials and the study of production processes that have the lowest impact on the environment with the aim of creating long-lasting products.

Sovet ha sempre mantenuto alta l'attenzione all'ecocompatibilità sin dalla sua nascita nel 1987, attraverso la selezione delle materie prime e lo studio di processi produttivi che abbiano il minimo impatto sull'ambiente con lo scopo di creare prodotti durevoli nel tempo.

photovoltaic systems



For its production processes, Sovet uses energy coming directly from renewable sources. Thanks to its photovoltaic systems, it is able to meet its own energy demand.

Per la sua produzione Sovet utilizza infatti energia derivante direttamente da fonti rinnovabili. Attraverso impianti fotovoltaici riesce a soddisfare il proprio fabbisogno energetico.



502695,549 kg emissions saved per year



2989 trees saved per year



165 barrels of oil saved per year

packaging



Sovet uses cardboard packaging with limited presence of oil-derivates.

Sovet usa imballi di cartone costruiti ad hoc con limitata presenza di derivati del petroli.



reducing plastic is an habits



To reduce the consumption of plastic and disposable bottles within its offices and production, Sovet created metal water bottles.

Per ridurre il consumo di plastica e bottiglie monouso all'interno dei suoi uffici e della produzione, Sovet ha creato delle borracce in metallo.

made in italy

The creative use of industrial processes, the use of raw materials of highest quality and the scrupulous work of master craftsmen, allow Sovet to create high quality and 100% Made in Italy collections. Thanks to state-of-the-art industrial automation systems, Sovet is also able to meet also large supply needs for contract spaces, always granting the highest quality standards. The company takes a continuous search path for materials, to create an offer of accessories that complement one another, furnishing different kinds of environments with the maximum freedom when it comes to customization.

L'impiego creativo dei processi industriali, l'utilizzo di materie prime di assoluta qualità e le scrupolose lavorazioni eseguite da maestranze artigiane, permettono a Sovet di ottenere collezioni di alta qualità e 100% Made in Italy. Grazie a sistemi di automazione industriale all'avanguardia Sovet è in grado di soddisfare anche esigenze per grandi forniture destinate a spazi contract, sempre garantendo i più elevati standard qualitativi. Sovet intraprende un percorso di ricerca dei materiali per creare un'offerta di complementi che si integrino tra di loro, arredando varie tipologie di ambienti con la massima possibilità di personalizzazione.

